

國立彰化師範大學 99 學年度碩士班招生考試試題

系所：工業教育與技術學系

組別：乙組(選考甲)

科目：自動控制

☆☆請在答案紙上作答☆☆

共 3 頁，第 1 頁

1. Please complete the describing differential equation for every ideal Element. (22%)

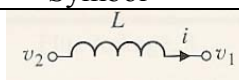
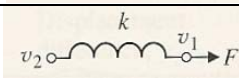
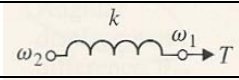
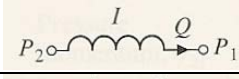
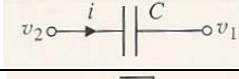
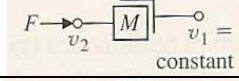
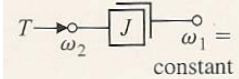
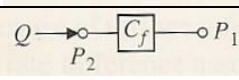
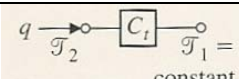
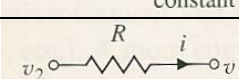
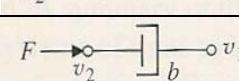
Physical Element	Describing Equation	Symbol
Electrical inductance		
Translational spring		
Rotational spring		
Fluid inertia		
Electrical capacitance		
Translational mass		
Rotational mass		
Fluid capacitance		
Thermal capacitance		
Electrical resistance		
Translational damper		

2. A closed-loop control system is shown in Fig.1. (10%)

(a) Determine the transfer function

$$T(s) = Y(s) / R(s).$$

(b) Determine the poles and zeros of $T(s)$.

(c) Use a unit step input, $R(s) = 1/s$, and obtain the partial fraction expansion for $Y(s)$ and the value of the residues.

(d) Plot $y(t)$ and discuss the effect of the real and complex poles of $T(s)$. Do the complex poles or the real poles dominate the response?

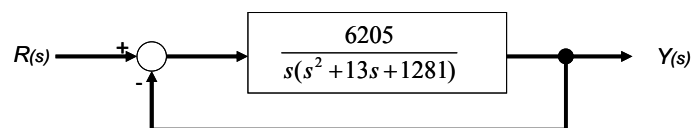

Fig.1

國立彰化師範大學 99 學年度碩士班招生考試試題

系所：工業教育與技術學系

組別：乙組(選考甲)

科目：自動控制

☆☆請在答案紙上作答☆☆

共 3 頁，第 2 頁

3. Please complete the following Laplace Transform Pairs. (18%)

$f(t)$	$F(s)$
Step function, $u(t)$	
e^{-at}	
$\sin \omega t$	
$\cos \omega t$	
$e^{-at} f(t)$	
t^n	
$f^{(k)}(t) = \frac{d^k f(t)}{dt^k}$	
$\int_{-\infty}^t f(t) dt$	
Impulse function $\delta(t)$	

4. Given the forward-path transfer function of unity-feedback control system

$$G(s) = \frac{K(s+3)}{s^4 + 7s^3 + 14s^2 + (8+k)s + 3k}$$

Apply the Routh-Hurwitz criterion to determine the range of K that will cause the system to be stable.

(15%)

5. Consider the regulator system

$$\dot{x} = Ax + Bu$$

where

$$A = \begin{bmatrix} 0 & 1 & 0 \\ 64.4 & 0 & -16 \\ 0 & 0 & -100 \end{bmatrix} \quad B = \begin{bmatrix} 0 \\ 0 \\ 100 \end{bmatrix}$$

The system uses the state feedback control $u = -Kx$. The desired closed-loop poles are $s_1 = -20$, $s_2 = -6 + j4.9$, and $s_3 = -6 - j4.9$. Determine the state feedback gain matrix K . (20%)

國立彰化師範大學 99 學年度碩士班招生考試試題

系所：工業教育與技術學系

組別：乙組(選考甲)

科目：自動控制

☆☆請在答案紙上作答☆☆

共 3 頁，第 3 頁

6. Find the state-space representation of the electrical network shown in Fig. 2. The output of the network is V_o . (15%)

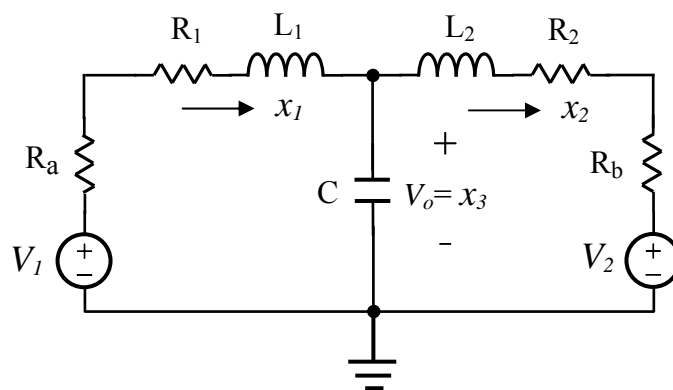

Fig.2