

國立彰化師範大學九十六學年度碩士班招生考試試題

系所：顯示技術研究所

科目：電子學

☆☆請在答案紙上作答☆☆

共 4 頁，第 1 頁

1. For the circuit shown in Fig.1, the transistor has $\beta=100$. Find:
(a) the small voltage gain v_o/v_s . (b) The input resistance R_{in} . (c) The output resistance R_o (15%)
2. For the circuit shown in Fig.2, the transistor has $\beta=100$, $V_{BE}=0.7V$, and $r_o=\infty$.
(a) Find R_E when $I_E = 150\mu A$. (b) Find A_d , and $CMRR_{dB}$ for a one-sided output at v_{o2} .
(c) Find the differential and common-mode input resistances. (25%)
3. For the circuit shown in Fig. 3, find:
(a) v_x and v_y in terms of v_1 and v_2 . (b) v_3 in terms of R , R_1 , R_2 , v_2 , and v_1 . (c) $A_d=v_o/(v_2-v_1)$. (15%)
4. For the circuit shown in Fig. 4, assuming the bias current to be about 1mA, $C_\mu=0.8pF$, $\beta=100$, and $f_T=600MHz$.
(a) Find the mid-band gain v_o/v_s . (b) Estimate the lower 3dB frequency f_L using the short circuit time constants method. (c) Estimate the upper 3dB frequency f_H . (25%)
5. For the circuit shown in Fig. 5, $g_{m1}=100mA/V$, $g_{m2}=50mA/V$, $h_{fe1}=h_{fe2}=100$, $r_{o1}=r_{o2}=\infty$.
(a) Identify the type of feedback. (b)The voltage gain v_o/v_s . (c) The input resistance R_{in} .
(d) The output resistance R_{out} . (20%)

國立彰化師範大學九十六學年度碩士班招生考試試題

系所：顯示技術研究所

科目：電子學

☆☆請在答案紙上作答☆☆

共 4 頁，第 2 頁

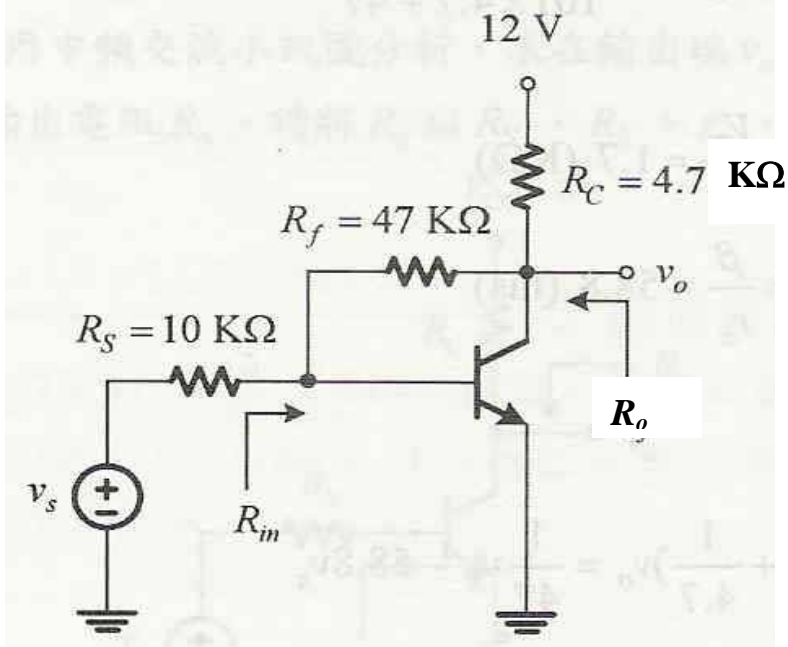

Fig. 1

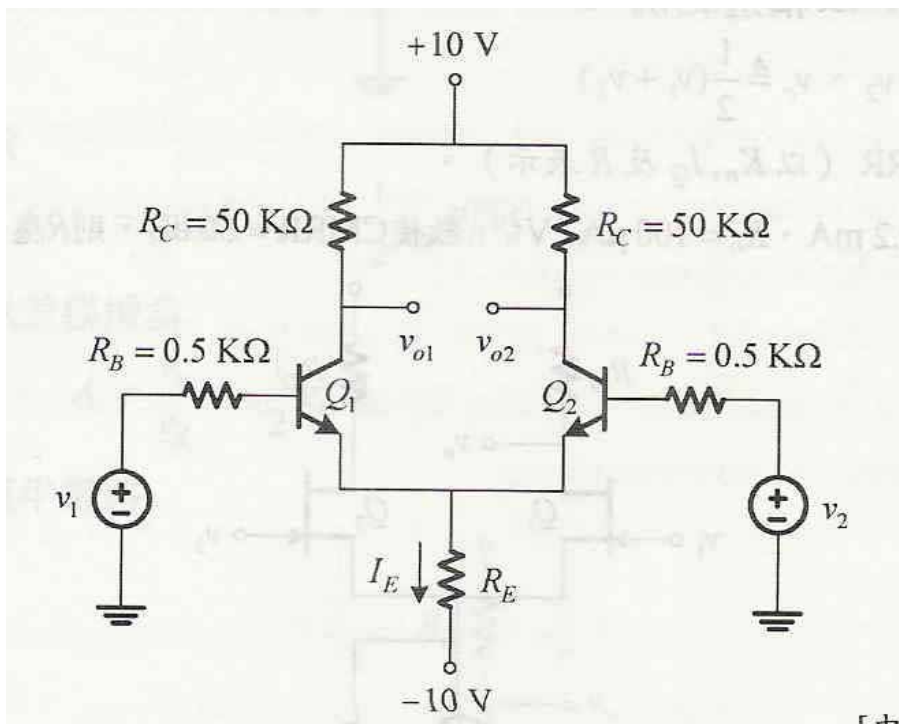

Fig. 2

國立彰化師範大學九十六學年度碩士班招生考試試題

系所：顯示技術研究所

科目：電子學

☆☆請在答案紙上作答☆☆

共 4 頁，第 3 頁

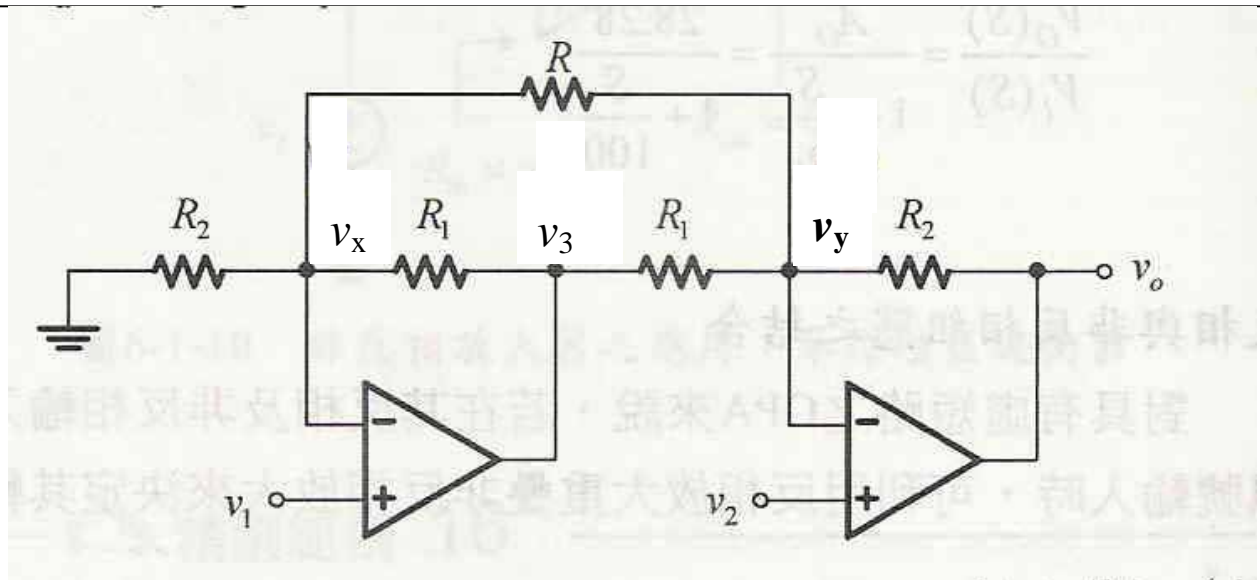

Fig. 3

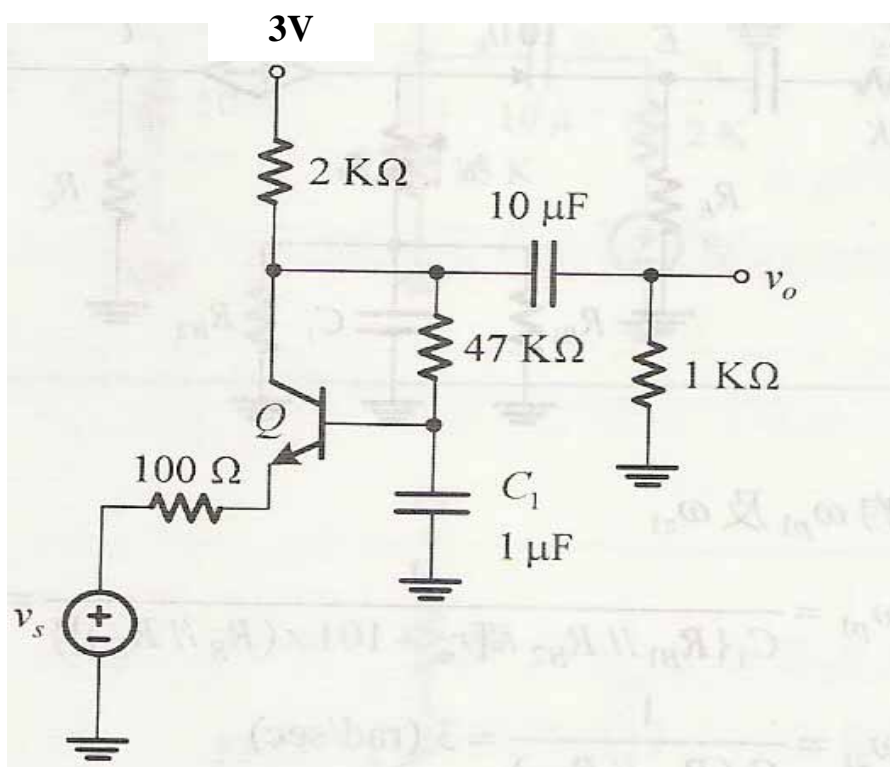

Fig. 4

國立彰化師範大學九十六學年度碩士班招生考試試題

系所：顯示技術研究所

科目：電子學

☆☆請在答案紙上作答☆☆

共 4 頁，第 4 頁

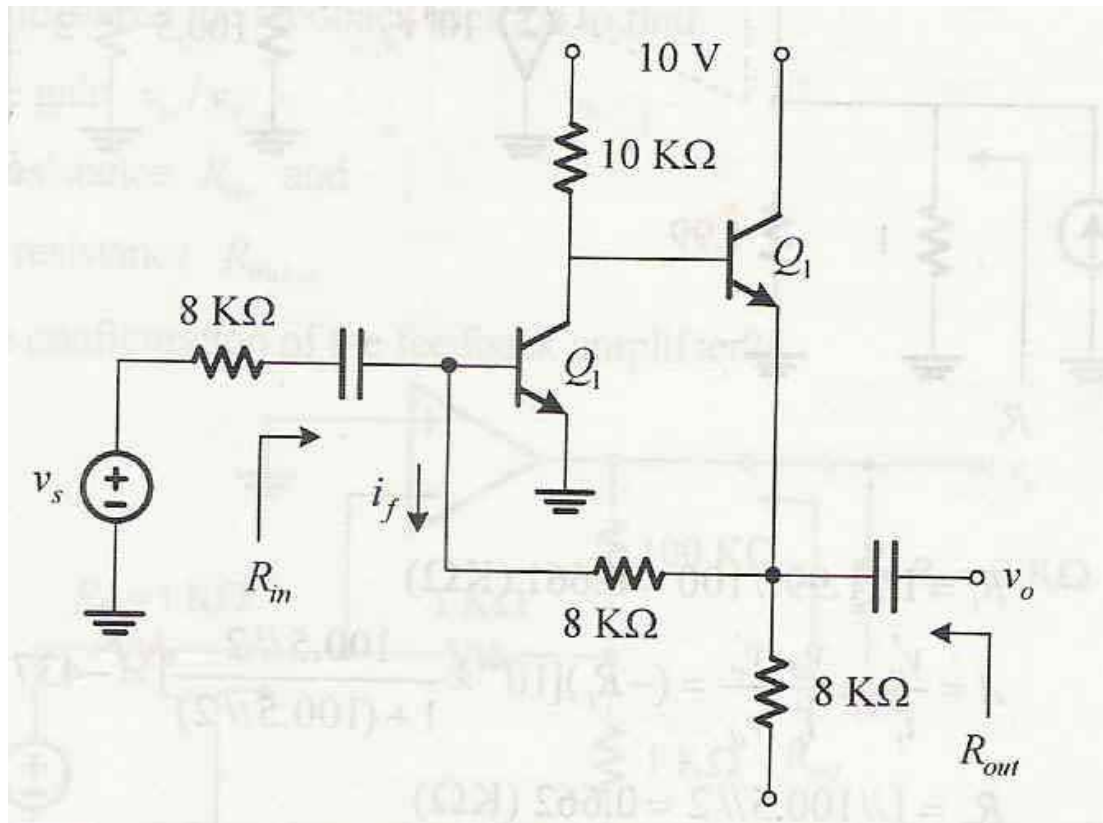

Fig. 5